

7. VBIC Background Information

VBIC Model History Notes

rev.1.2 updates

Sept. 24, 1999

3-terminal version defined
 Base-emitter breakdown model added
 Reach-through model added for B-C depletion capacitance
 Homotopy version of code added
 Limited exponential version added
 Completely new code generation added
 C, FORTRAN, Verilog-A, Perl, and MAST code provided
 Bug in psibi mapping with temperature fixed
 Bugs in electrothermal derivatives and solver stamp fixed
 DTEMP local temperature difference parameter added
 VERS and VREV (version revision) parameters added
 NKF high current beta rolloff parameter added
 Temperature dependence added to IKF
 Ability to select SGP qb formulation added (QBM)
 Ability to separate IS for fwd and rev added (ISRR)
 Fixed collector-substrate capacitance added (CCSO)
 Separate temperature coeffs added for RCX, RBX, RBP
 tl node eliminated
 POLARITY OF SOME BRANCHES REVERSED FOR VERILOG-A COMPATIBILITY
 > Ith flows from dt to ground and so is negative
 > Ixzf flows from xf1 to ground as so is negative of Itzf
 Igc component moved into Ibc
 Icc broken into forward and reverse components, Itxf or Itzf and Itzr

Release 1.2

Sept. 18, 1999

1.1.5 updates

July 28, 1996

Dependence of Irbp on Vbci added to "branch currents"
 Itf/Itr renamed Itfi/Itri to avoid name conflicts
 Resistor collapse and code bypass condition changed from par = 0 to par <= 0
 Branch current and charge dependencies separated for self-heating and no self-heating
 Depletion charge and avalanche routines that provide derivatives for self-heating added
 Self-heating solver and examples added (HBT)
 Extra external node added for self-heating to allow coupling of thermal models
 between devices

1.1.4 updates

Qbe diffusion term made equivalent to SGP (divide by qb)
 Solver example including excess phase added (Icc separated into Itzf|Itxf and Itzr for this)
 Error in sgp_to_vbic in PTF to TD translation fixed

1.1.3 updates

- Ith bug fixed and Igc term added
- BFN exponent added to 1/f noise
- RTH default changed to zero
- parameter aliases added

1.1.2 updates

- EAI bug fixed in PE/PC/PS temperature mapping
- Single->double precision in decomp/solve/vbict/QCDEPL
- Scale changed to vscale in solver to avoid name conflict
- Avalanche model added, element Igc
- Initialization changed in solver
- AC solver and AC and temperature tests added
- Missing term in derf_Vrci added
- Potential numerical problem in Irci fixed

1.1.1 updates

- VJ->V bug fixed in qj definition
- Potential numerical problems with ITF fixed
- Typo derf_Vcci fixed to derf_Vrci in FORTRAN code

SDD – Definition of the VBIC 1.1.4 Model in MDS

Although the toolkit is aimed to use the VBIC implementation in ADS (optional HSpice, Eldo, Spectre etc.), the following MDS definition of the VBIC model (rev.4. version 1.1.4), implemented as “Symbolically Defined Device“ (SDD), may be interesting to study.

This example is provided with the toolkit as *vbicsdd.inc*.

Note: the '\' sign means continuation with the next line.

```
sdd:COMP1 B 0 C 0 E 0 S 0 \
    V_bi 0 V_ci 0 V_ei 0 V_si 0 V_cx 0 V_bx 0 V_bp 0 V_th 0 V_cxf 0 V_rxf 0 \
    i[5,0]=ibi \
    i[5,1]=qbe+qbc+qbcx \
    i[6,0]=ici \
    i[6,1]=-qbc \
    i[7,0]=iei-ire \
    i[7,1]=-qbe-qbex \
    i[8,0]=isi-irs \
    i[8,1]=qbcx \
    i[9,0]=icx-ircx \
    i[9,1]=-qbcx \
    i[10,0]=ibx-irbx \
    i[10,1]=qbex+qbep \
    i[11,0]=ibp \
    i[11,1]=-qbep-qbcx \
    i[12,0]=irth-Ptot \
    i[12,1]=qcth \
    f[1,0]=ib-irbx \
    f[1,1]=-qbeo-qbcx \
    f[2,0]=ic-ircx \
    f[2,1]=qbco \
    f[3,0]=ie-ire \
    f[3,1]=qbeo \
    f[4,0]=vs - irs*RS_T - vsi \
    f[13,0]=itzf - itxf \
    f[13,1]=-qcx \
    f[14,0]=vcxf - vrxf \
    f[14,1]=-flxf
ics:COMP255 V_cx 0 idc=0
ics:COMP256 V_bp 0 idc=0
ics:COMP257 V_bx 0 idc=0
ics:COMP252 V_si 0 idc=0
ics:COMP253 V_ci 0 idc=0
ics:COMP251 V_ei 0 idc=0
ics:COMP250 V_bi 0 idc=0
ics:COMP254 V_th 0 idc=0
ics:COMP270 V_cxf 0 idc=0
ics:COMP271 V_rxf 0 idc=0
ie=_i3
irs=_i4
ic=_i2
ib=_i1
vci = _V6
vbi = _V5
vs = _V4
ve = _V3
vc = _V2
```

```

vb = _V1
delt = _V12
vrx = _V14
vcxf = _V13
PE_T = psibi(PE,EAIE)
PC_T = psibi(PC,EAIC)
PS_T = psibi(PS,EAIS)
GAMM_T = GAMM * (rT ^ XIS * exp(-EA * (1.0 - rT) / vtv))
VO_T = VO * rT ^ XVO
CJCP_T = CJCP * (PS / PS_T) ^ MS
CJEP_T = CJEP * (PC / PC_T) ^ MC
CJC_T = CJC * (PC / PC_T) ^ MC
CJE_T = CJE * (PE / PE_T) ^ ME
NR_T = NR * (1.0 + TNF * (tdev - tini))
NF_T = NF * (1.0 + TNF * (tdev - tini))
IBCNP_T = IBCNP * (rT ^ XIN * exp(-EANS * (1.0- rT) / vtv)) ^ (1.0 / NCNP)
IBCIP_T = IBCIP * (rT ^ XII * exp(-EAIS * (1.0- rT) / vtv)) ^ (1.0 / NCIP)
IBCN_T = IBCN * (rT ^ XIN * exp(-EANC * (1.0- rT) / vtv)) ^ (1.0 / NCN)
IBENP_T = IBENP * (rT ^ XIN * exp(-EANC * (1.0- rT) / vtv)) ^ (1.0 / NCN)
IBEIP_T = IBEIP * (rT ^ XII * exp(-EAIC * (1.0- rT) / vtv)) ^ (1.0 / NCI)
IBCI_T = IBCI * (rT ^ XII * exp(-EAIC * (1.0- rT) / vtv)) ^ (1.0 / NCI)
IBEN_T = IBEN * (rT ^ XIN * exp(-EANE * (1.0- rT) / vtv)) ^ (1.0 / NEN)
IBEI_T = IBEI * (rT ^ XII * exp(-EAIE * (1.0- rT) / vtv)) ^ (1.0 / NEI)
ISP_T = ISP * (rT ^ XIS * exp(-EA * (1.0- rT) / vtv)) ^ (1.0 / NFP)
IS_T = IS * (rT ^ XIS * exp(-EA * (1.0- rT) / vtv)) ^ (1.0 / NF)
RBP_T = RBP * rT^XRC
RS_T = RS * rT^XRS
RE_T = RE * rT^XRE
RBI_T = RBI * rT^XRB
RBX_T = RBX * rT^XRB
RCI_T = RCI * rT^XRC
RCX_T = RCX * rT^XRC
AVC2_T = AVC2 * (1.0 + TAVC * (ftdev - tini))
iei = -icc-ibe-ibex
irbp = vrbp * qbp / RBP_T
irbi = vrbi * qb / RBI_T
irci = iohm / sqrt(1.0 + derf * derf)
derf = IVO * RCI_T * iohm / (1.0 + 0.5 * IVO * IHRCF * (sqrt(vrci * vrci + 0.01)))
iohm = (vrci + vtv * (kbcj - kbcx - ln(rkp1))) / RCI_T
rkp1 = (kbcj + 1.0) / (kbcx + 1.0)
kbcx = if (RCI==0.0) then 0.0 else sqrt(1.0 + GAMM_T * exp(vbcx / vtv)) endif
kbcj = if (RCI==0.0) then 0.0 else sqrt(1.0 + GAMM_T * exp(vbcj / vtv)) endif
vbcx = vbcj - vrci
qbco = CBCO*vbc
qbeo = CBEO*vbe
qbcp = CJCP_T*qdbcp
qbep = TR*itfp+CJEP_T*qdbep
qbcx = QCO*kbcx
qbc = TR*itr+CJC_T*qdbc+QCO*kbcj
qbex = CJE_T*qdbex*(1.0-WBE)
qbe = tff*it_f/qb+CJE_T*qdbe*WBE
sITF = if (ITF<=0.0) then 1.0 else 0.0 endif
IHRCF = if (HRCF<=0.0) then 0.0 else 1.0/HRCF endif
ITF = if (ITF<=0.0) then 0.0 else 1.0/ITF endif
IVTF = if (VTF<=0.0) then 0.0 else 1.0/VTF endif
IVO = if (VO_T<=0.0) then 0.0 else 1.0/VO_T endif
IIKP = if (IKP<=0.0) then 0.0 else 1.0/IKP endif
IIKF = if (IKF<=0.0) then 0.0 else 1.0/IKF endif
IIKR = if (IKR<=0.0) then 0.0 else 1.0/IKR endif
IVER = if (VER<=0.0) then 0.0 else 1.0/VER endif
IVEF = if (VEF<=0.0) then 0.0 else 1.0/VEF endif
tff= TF*(1.0+QTF*q1)*(1.0+XTF*exp(vbcj*IVTF/1.44)*(sITF+(ritf/(ritf+1.0))^2)*sgitf)

```

```

ritf= it_f*sgitf*IITF
sgitf= if (it_f>0.0) then 1.0 else 0.0 endif
ibc = diode(vbci,IBCI_T,NCI)+diode(vbci,IBCN_T,NCN)
ibex = (1.0-WBE)*(diode(vbex,IBEI_T,NEI)+diode(vbex,IBEN_T,NEN))
ibe = WBE*(diode(vbei,IBEI_T,NEI)+diode(vbei,IBEN_T,NEN))
iccp = (itfp-itrp)/qbp
qbp = 0.5*(1.0+sqrt(1.0+4.0*q2p))
q2p = itfp*IIKP
itrp = diode(vbcp, ISP_T, NFP)
itfp = ISP_T*(WSP*exp(vbep/(NFP*vtv)))+(1.0-WSP)*exp(vbci/(NFP*vtv))-1.0)
CEP = if (TD<=0.0) then 0.0 else TD endif
LEP = if (TD<=0.0) then 0.0 else TD/3.0 endif
icc= if (TD>0.0) then itxf-itzr else itzf-itzr endif
itxf = vrxf
qcx = CEP*vcxf
flxf = LEP*itxf
itzr = itr/qb
itzf = it_f/qb
qb = 0.5*(q1+sqrt(q1*q1+4.0*q2))
q2 = it_f*IIKF+itr*IIKR
q1 = 0.5*(sqrt((q1z-0.0001)^2+0.0001*0.0001)+q1z-0.0001)+0.0001
q1z = 1.0+qdbbe*IVER+qdbc*IVEF
itr = diode(vbci, IS_T, NR_T)
it_f = diode(vbei, IS_T, NF_T)
rT = tdev / tini
tini = TNOM + tabs
qdbcp = qj(vbcp,PS_T,MS,FC,AJS)
qdbc = qj(vbci,PC_T,MC,FC,AJC)
qdbep = qj(vbep,PC_T,MC,FC,AJC)
qdbex = qj(vbex,PE_T,ME,FC,AJE)
qdbe = qj(vbei,PE_T,ME,FC,AJE)
icx = irci+irbp
vrbp = vcx-vbp
vrs = vs-vsi
vbcp = vsi-vbp
vbep = vbx-vbp
vre = ve-vei
vrbi = vbx-vbi
vrbx = vb-vbx
vbex = vbx-vei
vrci = vcx-vci
vrcx = vc-vcx
vei = _V7
vbp = _V11
vbx = _V10
vcx = _V9
vsi = _V8
tabs = 273.15
qq = 1.602189E-19
kb = 1.380662E-23
qsingle(v,p,f,a,m) = ql0(v,p,f,a,m)+(1.0-f)^(-m)*(v-vl(v,p,f,a)+vl0(p,f,a))-q0(p,f,a,m)
vl(v,p,f,a) = 0.5* (dvh(v,p,f)-mv(v,p,f,a))+p*f
mv(v,p,f,a) = sqrt(dvh(v,p,f)*dvh(v,p,f)+a)
ql0(v,p,f,a,m) = -p*(1.0-vl(v,p,f,a)/p)^(1.0-m)/(1.0-m)
q0(p,f,a,m) = -p*(1.0-vl0(p,f,a)/p)^(1.0-m)/(1.0-m)
vl0(p,f,a) = 0.5* (dv0(p,f)-mv0(p,f,a))+p*f
mv0(p,f,a) = sqrt(dv0(p,f)*dv0(p,f)+a)
dv0(p,f) = dvh(0,p,f)
qspice(v,p,m,f) = ql0(v,p,f,m)+qhi(v,p,f,m)
qhi(v,p,f,m) = if (dvh(v,p,f)>0.0) then dvh(v,p,f)*(1.0-f+0.5*m*dvh(v,p,f)/p)/((1.0-f)^(1.0+m)) \
else 0.0 endif
ql0(v,p,f,m) = if (dvh(v,p,f)>0.0) then p*(1.0-(1.0-f)^(1.0-m))/(1.0-m) \

```

```

else p*(1.0-(1.0-v/p)^(1.0-m))/(1.0-m) endif
dvh(v,p,f) = v-f*p
qj(v,p,m,f,a) = if (a<=0.0) then qspice(v,p,m,f) else qsingle(v,p,f,a,m) endif
vtv = kb * tdev / qq
diode(v,is,n) = is*(exp(v/(n*vtv)) - 1)
vbci = vbi-vci
vbc = vb-vc
vbe = vb-ve
vbei = vbi-vei
isi = ibcp-iccp
ibp = -ibep-irbp-ibcp
ibx = ibex+irbi+ibep+iccp
psiio(p) = 2.0 * vtv * ln(exp(.5 * p / vtv)-exp(-0.5 * p / vtv))
psiin(p,e_a) = psiio(p) * rT - 3.0 * vtv * ln(rT) - e_a * (rT - 1.0)
psibi(p,e_a) = psiin(p,e_a) + 2.0 * vtv * ln(0.5 * (1.0 + sqrt(1.0 + 4.0 * exp(-psiin(p,e_a) / vtv))))
tdev = if (RTH>0) then TAMB + tabs + delt else TAMB + tabs endif
Ptot = if (RTH>0) then ibe*vbei+(ibc-igc)*vbci+icc*(vbei-vbci)+ibep*vbe+ibcp*vbc+iccp* \
(vbep-vbcp)+ircx*vrcx+irci*vrci+irbx*vrbx+irbi*vrb+ire*vre+irbp*vrbp+irs*vrs+ibex*vbex \
else 0.0 endif
irth = if (RTH>0) then delt / RTH else 0.0 endif
qcth = if (CTH>0) then CTH * delt else 0.0 endif
igc = if (AVC1==0.0) then 0 else (itzf-itzr-ibc)*avalm(vbci,PC_T,MC,AVC1,AVC2_T) endif
ibi = ibe+ibc-igc-irbi
ici = icc-ibc+igc-irci
vla(v,p) = 0.5 * (sqrt((p-v)^2 + 0.01) + (p-v))
avalm(v,p,m,av1,av2) = av1 * vla(v,p) * exp(-av2 * vla(v,p)^(m - 1.0))
ibep= if (IBEIP==0.0 && IBENP==0.0) then 0.0 else /
diode(vbep,IBEIP_T,NCI)+diode(vbep,IBENP_T,NCN) endif
ibcp= if (IBCIP==0.0 && IBCNP==0.0) then 0.0 else /
diode(vbcp,IBCIP_T,NCIP)+diode(vbcp,IBCNP_T,NCNP) endif
irbx = if (RBX_T <= 0.0) then 1E-15 else (vb-vbx)/RBX_T endif
ircx = if (RCX_T <= 0.0) then 1E-15 else (vc-vcx)/RCX_T endif
ire = if (RE_T <= 0.0) then 1E-15 else (ve-vei)/RE_T endif
R:CMP272 0 V_cxf r=1E20 OH
R:CMP273 0 V_bx r=1E20 OH
R:CMP274 0 V_bi r=1E20 OH
R:CMP275 0 V_rxf r=1E20 OH
R:CMP276 0 V_th r=1E20 OH
R:CMP277 0 V_cx r=1E20 OH
R:CMP278 0 V_bp r=1E20 OH
R:CMP279 0 V_ei r=1E20 OH
R:CMP280 0 V_ci r=1E20 OH
R:CMP281 0 V_si r=1E20 OH

```

SIMPLIFIED VBIC EQUATIONS, rev. 1.1.4:

Main transistor Collector current without the case check for parameter=0, and without temperature effects

```

ici = icc - ibc + igc - irci
>>   icc= itxf - itzr
      itxf = vrxf, with   vrxf = _V14
      itzr = itr/qb
      itr = diode(vbci, IS_T, NR_T)
      diode(v, is, n) = is*(exp(v/(n*vtv)) - 1)
      qb = 0.5*(q1+sqrt(q1*q1+4.0*q2))
>>   ibc = diode(vbci, IBCI_T, NCI)+diode(vbci, IBCN_T, NCN)

      igc = itzf - itzr - ibc) * avalm(vbci, PC_T, MC, AVC1, AVC2_T)
      itzf = it_f/qb
      it_f = diode(vbei, IS_T, NF_T)
      itzr = itr/qb
      itr = diode(vbci, IS_T, NR_T)
      ibc = diode(vbci, IBCI_T, NCI)+diode(vbci, IBCN_T, NCN)
>>   irci = iohm / sqrt(1.0 + derf ^2)
      iohm = (vrcki + vtv * (kbcj - kbcx - ln(rkp1))) / RCI_T
      vrcki = vcx-vcj

```

Main transistor Base current without the case check for parameter=0, and without temperature effects

Different to the SGP model, the Base-Emitter current is defined independent from the Collector-Emitter current. No beta parameter is used (i.e. no BF with the VBIC model). The Base Emitter current consists of an ideal and a nonideal part, both divided into an intrinsic (I_{be}) and an extrinsic (I_{bex}) part by the geometrical parameter WBE:

For version 1.1.4, there is:

$$I_{be} = WBE * \left[IBEI \left(\exp \frac{V_{bei}}{NEI * V_T} - 1 \right) + IBEN \left(\exp \frac{V_{bei}}{NEN * V_T} - 1 \right) \right]$$

and

$$I_{bex} = (1 - WBE) * \left[IBEI \left(\exp \frac{V_{bex}}{NEI * V_T} - 1 \right) + IBEN \left(\exp \frac{V_{bex}}{NEN * V_T} - 1 \right) \right]$$

The Base-Collector current is defined independent of the inverse transport a current as well:

$$I_{bc} = IBCI \left(\exp \frac{V_{bci}}{NCI * V_T} - 1 \right) + IBCN \left(\exp \frac{V_{bci}}{NEN * V_T} - 1 \right)$$

Paras transistor Collector current without the case check for parameter=0, and without temperature effects

$$I_{fp} = I_{sp} * (WSP * \exp(v_{bep}/(NFP * vt)) + (1 - WSP) * \exp(v_{bci}/(NFP * vt)) - 1)$$

Information on the VBIC Code, Release 1.2.

For a short synopsis of the changes see the chapter "History".

Here is a list of the major changes in version 1.2:

1. The name is now VBIC and not VBIC95.
2. The thermal network has been returned to its original form, which was how it was implemented in all simulators anyway.
The "tl" node was incorrect, the Ith current had to circulate from dt to tl and so could not allow tl to function as a coupling node. Ith has to have one end grounded.
Note: this means that the value of RTH used for single device self-heating differs from that used when a thermal network couples more than one device.
3. All of the model additions agreed to at the BCTM meetings have been implemented
 - temperature dependence of IKF
 - separate temperature coefficients for intrinsic and extrinsic resistances
 - a 3 terminal version
 - base-emitter breakdown model (simple exponential)
 - reach-through model to limit base-collector depletion capacitance
 - VERS version parameter added (also VREV for version revision)
 - separate activation energy added for ISP
4. Additional changes were made based on feedback from many sources
 - errors in solvers and derivatives for electrothermal model fixed
 - simple continuation added to improve solver convergence
 - QBM parameter add to switch to SGP qb formulation
 - NKF added to parameterize beta(Ic) high-current rolloff
 - fixed collector-substrate capacitance added (CCSO)
 - for HBTs, ISRR added to allow separate IS for reverse operation
 - an error in the built-in potential temperature mapping was fixed
 - code bypass for efficiency, if some parameters are zero
 - limited exponential version provided
 - the transport current Icc was explicitly separated into forward and reverse components
5. The automated code generation has been completely rewritten.
All code, including solvers, is now generated. Solvers exist for all combinations of the code.
6. **IMPORTANT:** note that the polarities of some of the current branches have changed. This was necessary because Verilog-A supports (or appears to support) branches to ground referenced from a node to ground, and not from ground to a node.
The Ith and Itzf branches in the thermal and excess phase networks are now defined as the negative of what they were, but the connection polarity is switched. Ith is now negative, but flows from dt to ground. This must be taken into account when setting up the matrix stamp properly.

Equivalent Circuit Network for VBIC 1.2:

- (->)- $\begin{matrix} | \\ \wedge \\ | \end{matrix}$ and $\begin{matrix} | \\ v \\ | \end{matrix}$ are voltage controlled current sources (arrow gives reference direction for current flow), key letter I
- + -
-||- and $\begin{matrix} | \\ + \\ = \\ | \\ - \end{matrix}$ are voltage controlled charge sources (+/- signs give reference polarity), key letter Q
- (=>)- are current controlled flux sources (arrow gives reference direction for flux), key letter F

resistors are depicted as voltage controlled current sources for generality (also, this is true if self-heating is modeled)

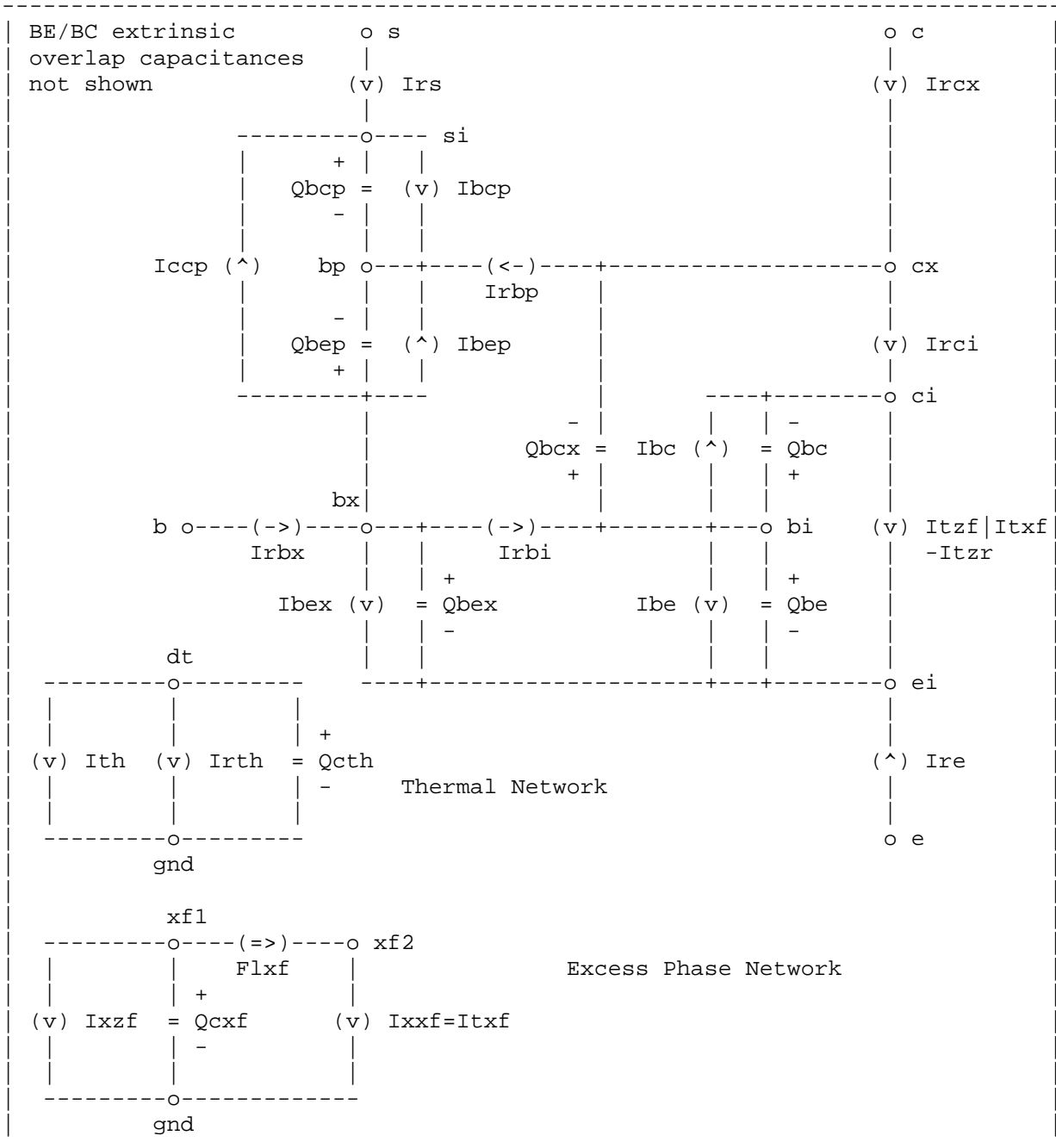

Default Parameters rev.1.2

VERS	1.2
VREV	0.0
Parameter Extraction Temperature	
TNOM	27.0
Local Temp. Dependence	
DTEMP	0.0
CV	
FC	0.9
CBEO	0.0
CJE	0.0
PE	0.75
ME	0.33
AJE	-0.5
CBCO	0.0
CJC	0.0
QCO	0.0
CJEP	0.0
PC	0.75
MC	0.33
AJC	-0.5
CJCP	0.0
PS	0.75
MS	0.33
AJS	-0.5
CCSO	0.0
Resistors	
RCX	0.0
RCI	0.0
VO	0.0
GAMM	0.0
HRCF	0.0
RBX	0.0
RBI	0.0
RE	0.0
RS	0.0
RBP	0.0
Early Voltage	
VEF	0.0
VER	0.0
Main Transistor	
IS	1.0e-16
NF	1.0
NR	1.0
IBEI	1.0e-18
WBE	1.0
NEI	1.0
IBEN	0.0
NEN	2.0
IBCI	1.0e-16
NCI	1.0
IBCN	0.0
NCN	2.0
AVC1	0.0
AVC2	0.0
IKF	0.0
NKF	0.5
IKR	0.0
ISRR	1.0

Parasitic Transistor	
ISP	0.0
WSP	1.0
NFP	1.0
IBEIP	0.0
IBENP	0.0
IBCIP	0.0
NCIP	1.0
IBCNP	0.0
NCNP	2.0
IKP	0.0
Thermal Model	
RTH	0.0
CTH	0.0
Transit Time	
TF	0.0
QTF	0.0
XTF	0.0
VTF	0.0
ITF	0.0
TR	0.0
TD	0.0
Flicker Noise	
KFN	0.0
AFN	1.0
BFN	1.0
Select SGP qB Formulation	
QBM	0.0
Temperature & Misc.	
EA	1.12
EAIE	1.12
EAIC	1.12
EAIS	1.12
EANE	1.12
EANC	1.12
EANS	1.12
XIS	3.0
XII	3.0
XIN	3.0
TNF	0.0
TAVC	0.0
VRT	0.0
ART	0.1
XRE	0
XRBI	0
XRCI	0
XRS	0
XRCX	0
XRBX	0
XRBP	0
XIKF	0
XVO	0
XISR	0.0
DEAR	0.0
EAP	1.12
VBBE	0.0
NBBE	1.0
IBBE	1.0e-6
TVBBE1	0.0
TVBBE2	0.0
TNBBE	0.0
EBBE	0.0

